

ชุดโกดตีโพสท์ แบบมาตรฐาน (แบบใช้น้ำมัน / แบบไม่ใช้น้ำมัน)
PLAIN GUIDE POST SETS (OIL TYPE / OIL-FREE TYPE)

MY (GPS)

MYP (GPSP) มีรูโดเวลพิน

① M FC250
 ② M S45C
 H 55HRC~(ขุ่นแข็งด้วยการชักนำกระแสไฟฟ้า ในสนามแม่เหล็ก)
 ③ M FC250

MYZ (แบบไม่ใช้น้ำมัน)

MYPZ (มีรูโดเวลพิน/แบบไม่ใช้น้ำมัน)

① M FC250
 MoS2 (แบบฝัง)
 ② M S45C
 H 55HRC~(ขุ่นแข็งด้วยการชักนำกระแสไฟฟ้า ในสนามแม่เหล็ก)
 ③ M FC250

D	A	B	a	b	d	H	H ₁	T	l	a ₁	b ₁	eH7	④ สกรู	⑤ โดเวลพิน
20	74	44	56	30	6.6	30	40	15	56	28	15	6	+0.012 0	CB 6-30 DPT 6-20
25	84	48	66	30	9	30	45	20	66	33	15	8	+0.015 0	CB 8-35 DPT 8-30
32	100	58	76	36	11	40	50	20	76	38	18	8	+0.015 0	CB10-40 DPT 8-30
38	130	75	100	44	11	50	60	25	100	50	22	10	+0.015 0	CB10-45 DPT 10-40
50	155	90	125	60	14	65	85	25	125	62.5	30	10	+0.018 0	CB12-50 DPT 10-40
60	190	120	150	80	18	75	100	30	150	75	40	13	+0.018 0	CB16-60 DPT 13-50
80	230	150	180	110	22	100	130	35	190	90	55	16	+0.018 0	CB20-75 DPT 16-60

Catalog No.		L	ราคา			
Type	D		MY	MYP	MYZ	MYZP
MY MYP MYZ MYZP	20	*80 *90 100 110 120				
		130 *140*150*160				
	25	*80 *90 100 110 120				
		130 140 150 160 *170*180*200				
	32	*90 100 110 120 130 140				
		150 160 *170*180*200*220*250				
	38	110 120 130 140 150 160 170 180				
		200 *220*250*280*300				
	50	160 170 180 200 *220*250				
		*280*300*350				
	60	180 200 *220*250*280*300				
		*350*400				
	80	*250*280*300*350				
		*400*450				

D
Standard Components
For Press Dies



ชุดไกด์โพสท์ แบบลูกปืน (สต็อปเปอร์แบบเคลื่อนตัวได้)

BALL BEARING GUIDE POST SETS (MOVABLE STOPPER)



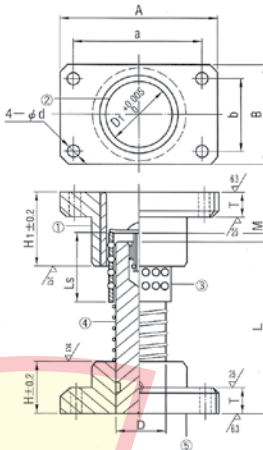

① ⑤ M FC250
② M SUJ2
③ H 58HRC~
④ M A5052S
④ M SUJ2
⑤ H 58HRC~(ขุ่นแข็งด้วยการชุบน้ำกะละแผลไฟฟ้า ในสนามแม่เหล็ก)

MYA (GPSB-A)
(ฝาครอบลูกบอลอะลูมิเนียม)

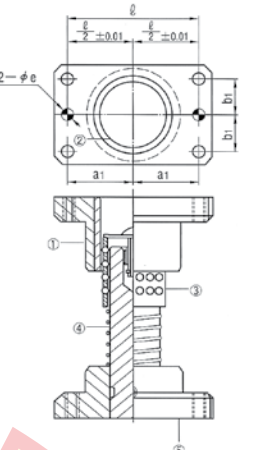

MYAP (GPBP-A)
(มีรูโตเวลพิน/ฝาครอบลูกบอลอะลูมิเนียม)





① ⑤ M FC250
② M SUJ2
③ H 58HRC~
④ M POM (ไฟลือะซีทีลเรซิน)
④ M SUJ2
⑤ H 58HRC~(ขุ่นแข็งด้วยการชุบน้ำกะละแผลไฟฟ้า ในสนามแม่เหล็ก)

MYJ (GPSB)
(แบบเรซิน)

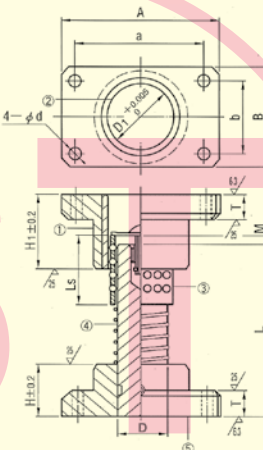

MYJP (GPBP)
(มีรูโตเวลพิน/แบบเรซิน)

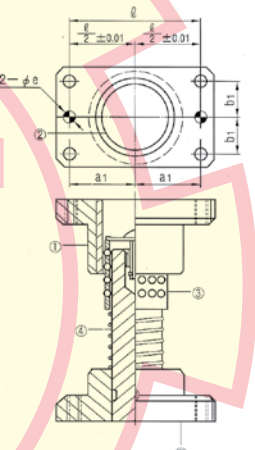

D	D ₁	A	B	a	b	d	H	H ₁	T	Ls	M	ℓ	a ₁	b ₁	eH7	④ สกรู	⑤ โตเวลพิน	
20	26	74	44	56	30	6.6	30	50	15	50	o~20	56	28	15	6	CB 6-30	DPT 6-20	
25	31	84	48	66	30	9	30	50	20	50	o~20	66	33	15	8		CB 8-35	DPT 8-30
32	40	100	58	76	36	11	40	60	20	60	o~25	76	38	18	8	CB10-40	DPT 8-30	
38	48	130	75	100	44	11	50	70	25	70	o~29	100	50	22	10		CB10-45	DPT 10-40
50	60	155	90	125	60	14	65	90	25	90	o~42	125	62.5	30	10		CB12-50	DPT 10-40

Catalog No. Type	D	L	ราคา			
			MYA	MYAP	MYJ	MYJP
MYA MYAP MYJ MYJP	20	*90 *100 *110 *120				
		*130 *140 *150 *160				
	25	*90 100 110 120				
		130 140 150 160				
	32	*170 *180 *200				
		110 120 130 140 150				
	38	160 170 180 200				
		*220 *240 *260				
	50	130 140 150 160				
		170 180 200 220				
			240 *260*300			
			170 180 200			
		220 240 *260				
		*300 *350				



ชุดโอดไฟสท์ แบบลูกปืน (สต๊อปเปอร์แบบยึดตายตัว)

BALL BEARING GUIDE POST SETS (FIXED STOPPER)

MYAK
(ฝาครอบลูกบอลอะลูมิเนียม)

MYKP
(มีรูโดเวลฟิน/ฝาครอบลูกบอลอะลูมิเนียม)

MYJK
(ฝาครอบลูกบอลเรซิน)

MJKP
(มีรูโดเวลฟิน/ฝาครอบลูกบอลเรซิน)

① ⑤ M FC250
 ② M SUJ2
 H 58HRC~
 ③ M A5052S
 ④ M SUJ2
 H 58HRC~(ขุ่นแข็งด้วยการชักนำกระแสไฟฟ้า ในสนามแม่เหล็ก)

① ⑤ M FC250
 ② M SUJ2
 H 58HRC~
 ③ M POM (ไฟลิ่งซีทีลเรซิน)
 ④ M SUJ2
 H 58HRC~(ขุ่นแข็งด้วยการชักนำกระแสไฟฟ้า ในสนามแม่เหล็ก)

D	D ₁	A	B	a	b	d	H	H ₁	T	K	E	L _s	ℓ	a ₁	b ₁	eH7	④ สกรู	⑤ โดเวลฟิน
20	31	84	48	66	30	9	30	50	20	20	5	50	66	33	15	8	CB 8-35	DPT 8-30
25	40	100	58	76	36	11	40	60	20	25	5	60	76	38	18	8		
32	48	130	75	100	44	11	50	70	25	30	10	70	100	50	22	10	CB10-40	DPT 8-30
38	60	150	90	125	60	14	65	90	25	40	10	90	125	62.5	30	10		
50	70	190	120	150	80	18	75	100	30	50	15	100	150	75	40	13	CB12-50	DPT 10-40
																	CB16-60	DPT 13-50

Catalog No. Type	D	L	ราคา			
			MYAK	MYKP	MYJK	MJKP
MYAK MYKP MYJK MJKP	25	*90 100 110 120				
		130 *140 *150 *160				
		*170 *180 *200				
	32	110 120 130 140 150				
		160 170 *180 *200				
		*220 *240 *260				
	38	130 140 150 160				
		170 180 *200 *220				
		*240 *260 *300				
	50	*170 *180 *200				
		*220 *240 *260				
		*300 *350				
60	*200 *220					
	*240 *260					
	*300 *350					

D
Standard Components
For Press Dies

S.T. MODERNTOL CO., LTD.
 TEL. 0 2417-0840 (ถัดในมัติ 8 สาย) FAX: 662-417-1441, 662-417-1484-5

ไกด์โฮลเดอร์

GUIDE HOLDERS

ไกด์โฮลเดอร์



MGH

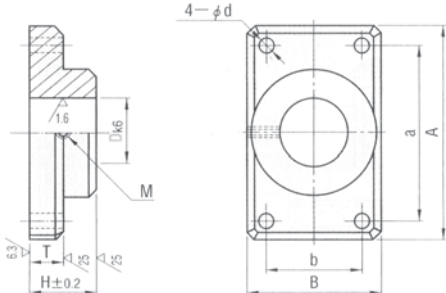

MGHP (มีรูโดเวลพิน)

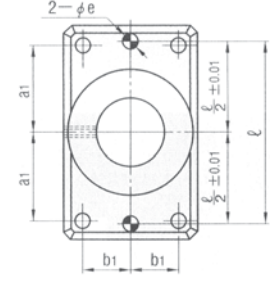

ต้นไกด์โฮลเดอร์เข้าไม่โดยการใช้อัดน้ำมันไฮดรอลิกขณะติดตั้ง

M FC250

Catalog No.		D		A	B	a	b	d	H	T	M	eH7	l	a1	b1	U/Price Q'ty: 1~9			
Type	D															MGH	MGHP		
MGH MGHP	20	+0.002 -0.011	74	44	56	30	6.6	30	15	8	6	+0.012 0	56	28	15				
	25		84	48	66	30	9	30	20				66	33	15				
	32	+0.003 -0.013	100	58	76	36	11	40	20			8	8	+0.015 0	76	38	18		
	38		130	75	100	44	11	50	25						100	50	22		
	50		155	90	125	60	14	65	25						125	62.5	30		
	60	+0.004 -0.014	190	120	150	80	18	75	30			12	13	+0.018 0	150	75	40		
80	230		150	180	110	22	100	35	16	190	90				55				

ไกด์บุชแบบมาตรฐาน



MGB

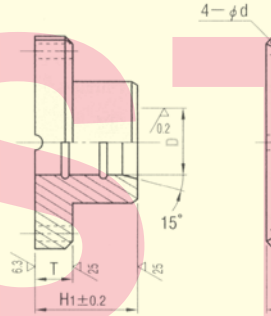

MGBP (มีรูโดเวลพิน)

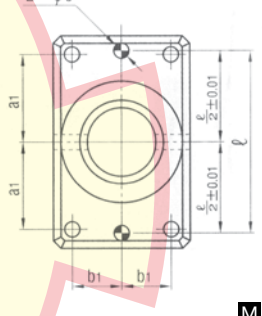

M FC250

ไกด์บุชแบบไม่ใช้น้ำมัน



MGBZ

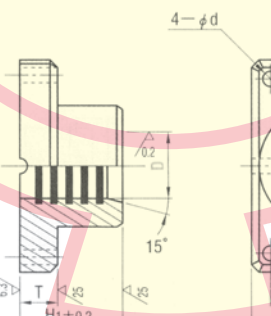

MGBZP (มีรูโดเวลพิน)

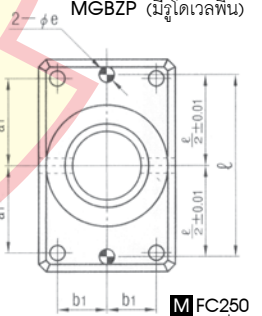

M FC250
สารหล่อลื่นความหนืดสูงชนิดพิเศษ (แบบฝัง)

Catalog No.		D		A	B	a	b	d	H1	T	eH7	l	a1	b1	U/Price Q'ty: 1~9					
Type	D														MGB	MGBP	MGBZ	MGBZP		
MGB MGBP MGBZ MGBZP	20	+0.041 +0.031	74	44	56	30	6.6	40	15	6	+0.012 0	56	28	15						
	25		84	48	66	30	9	45	20			66	33	15						
	32	+0.047 +0.037	100	58	76	36	11	50	20			8	+0.015 0	76	38	18				
	38		130	75	100	44	11	60	25					100	50	22				
	50		155	90	125	60	14	85	25					125	62.5	30				
	60	+0.061 +0.043	190	120	150	80	18	100	30			13	+0.018 0	150	75	40				
	80		230	150	180	110	22	130	35					16	190	90	55			



โก๊ตบุชแบบลูกปืน

BALL GUIDE BUSHINGS

โก๊ตบุชแบบลูกปืน



MAB

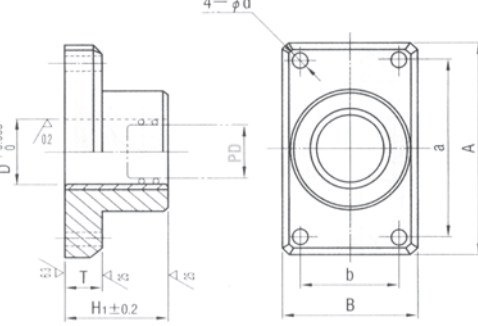

MABP (มีรูโดเวลพิน)

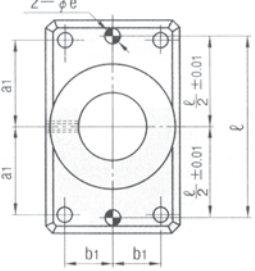

บุชที่ประกอบแล้ว
M FC250 M SUJ2 H 58HRC~

Catalog No.		PD	D	A	B	a	b	d	H1	T	eh7	ℓ	a1	b1	U/Price Q'ty: 1~9		
Type															MAB	MABP	
MAB MABP	20	26	+0.005 0	74	44	56	30	6.6	50	15	6	+0.012 0	56	28	15		
	25	31		84	48	66	30	9	50	20	8		+0.015 0	66	33	15	
	32	40		100	58	76	36	11	60	20	10	76		38	18		
	38	48		130	75	100	44	11	70	25	10	100		50	22		
	50	60		155	90	125	60	14	90	25	10	125		62.5	30		
	60	70		190	120	150	80	18	100	30	13	+0.018 0	150	75	40		

โก๊ตโพสท์

GUIDE POSTS

โก๊ตโพสท์



MGP (สำหรับ MY , MYP)
 MGPT (แบบมีเกลียว สำหรับ MYJ , MYJP)

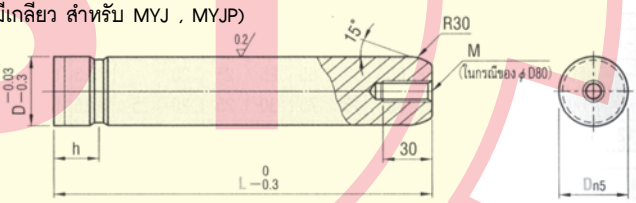

M S45C
H 55HRC~

ต้นโก๊ตโพสท์เข้าไยโดยการใชการอัดน้ำมันไฮดรอลิกขณะติดตั้ง
 (ขุมแข็งด้วยการชักนำกระแสไฟฟ้าในสนามแม่เหล็ก)

Dn5	h	M	Catalog No.		L	ราคา		
			Type	D		MGP	MGPT	
20	+0.024 +0.015	15	-	MGP MGPT	20	80 90 100 110 120		
					20	130 140 150 160		
25	15	-	25		80 90 100 110 120			
			25		130 140 150 160 170 180 200			
32	+0.028 +0.017	20	-		32	90 100 110 120 130 140		
					32	150 160 170 180 200 220 250		
38	+0.028 +0.017	25	-	38	110 120 130 140 150 160 170 180			
				38	200 220 250 280 300			
50	+0.033 +0.020	32.5	-	50	160 170 180 200 220 250			
				50	280 300 350			
60	+0.033 +0.020	37.5	-	60	180 200 220 250 280 300			
				60	350 400			
80	+0.033 +0.020	50	12	80	250 280 300 350			
				80	400 450			

D

Standard Components
For Press Dies



สต๊อปเปอร์ / สปริงสำหรับชุดไกด์โพสแบบลูกปืน

STOPPERS / SPRINGS FOR BALL GUIDE POST SETS

สต๊อปเปอร์



STMY

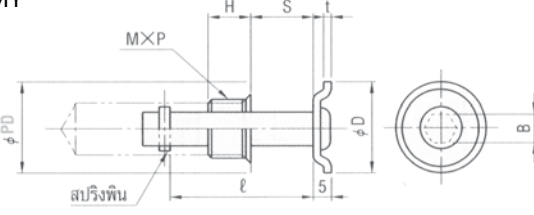

MBS/MBJ	STMY	
Ball cage length	S	l
50	0~20	32
60	0~25	40
70	0~29	44
90	0~42	57

Catalog No.		D	M x P	H	B	t	U/Price
Type	PD-L						Q'ty: 1~9
STMY	20-25	24	14 x 1.5	12	7	1.6	
	25-50	29	16 x 1.5		8		
	32-60	37					
	38-70	44	20 x 1.5	15	10		
	50-90	56					2.0



STM (สต๊อปเปอร์แบบเคลื่อนตัวได้)

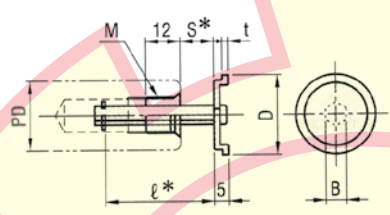

* ขึ้นกับความยาวของฝาครอบลูกบอล
M S45C, SPC-1 (ฝาครอบสต๊อปเปอร์)
S รมดำ (Fe3O4)



STK (สต๊อปเปอร์แบบยึดตายตัว)

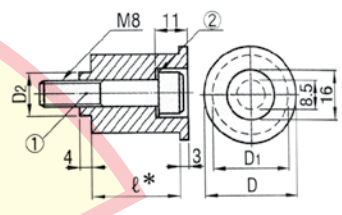

* ขึ้นกับความยาวของฝาครอบลูกบอล
M S45C
S รมดำ (Fe3O4)
A ① CB ② ทวนรองสปริง

PD Post diameter	D	M x P	B	t	D1	D2	Spring washer	Catalog No.		L		U/Price
								Type	PD	Ball cage length	Q'ty: 1~9	
20	24	10 x 1.5	5	1.6	19	14	เส้นผ่าศูนย์กลาง โน้มนอลตาม JIS B1251-1984 เท่ากับ 8 มม.	STM (สต๊อปเปอร์แบบเคลื่อนตัวได้)	20	50		
22	26								22	50	60	
25	29								25	60	75	
28	33								28	60	75	
32	37								32	75	90	
38	44	16 x 1.5	8	2.0	20			STK (สต๊อปเปอร์แบบยึดตายตัว)	38	75	90	
45	51								45	90	110	
50	56								50	90	110	
60	66								60	90	110	

Ball cage length	STM		STK	
	S	l	l	① CB
50	0~19	31	15	8-30
60	0~23	35	20	8-35
75	0~30	42	25	8-40
90	0~37	49	30	8-45
110	0~47	59	35	8-50

สปริงสำหรับชุดไกด์โพสแบบลูกปืน



SWMY

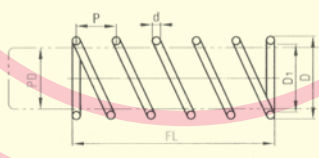

M SWP-B

PD Post diameter	D	D1	d	P
20	22.5	20.5	+1.0	1.0
25	27.9	25.5	0	1.2
32	35.7	32.5	+1.5	1.6
38	42.5	38.5	0	2.0
50	55.7	50.5	+2.0	2.6
60	66.9	60.5	0	3.2

* โหลดสปริง = $\frac{FL \times d}{P} + 2d$

Guide post sets		Catalog No.		FL	U/Price			
D	L	Type	PD			Q'ty: 1~9		
20	90	SWMY	20	40				
	100			50				
	110			70				
	120			80				
	130			100				
	140			110				
	150			120				
	160			140				
	25			90	SWMY	25	40	
				100			50	
110		70						
120		80						
130		100						
140		110						
150		120						
160		140						
170		150						
180		160						

Guide post sets		Catalog No.		FL	U/Price
D	L	Type	PD		
32	110	SWMY	32	50	
	120			60	
	130			70	
	140			80	
	150			100	
	160			110	
	170			120	
	180			130	
	190			140	
	200			170	
38	130	SWMY	38	60	
	140			70	
	150			80	
	160			90	
	170			110	
	180			120	
	190			130	
	200			140	
	210			150	
	220			170	

Guide post sets		Catalog No.		FL	U/Price			
D	L	Type	PD			Q'ty: 1~9		
50	170	SWMY	50	70				
	180			90				
	200			110				
	220			140				
	240			170				
	260			190				
	280			230				
	300			280				
	60			200	SWMY	60	90	
				220			130	
240		150						
260		180						
300		230						
350		250						



D
 Standard Components
 For Press Dies

BALL BEARING GUIDE POST SETS (REMOVABLE POST)

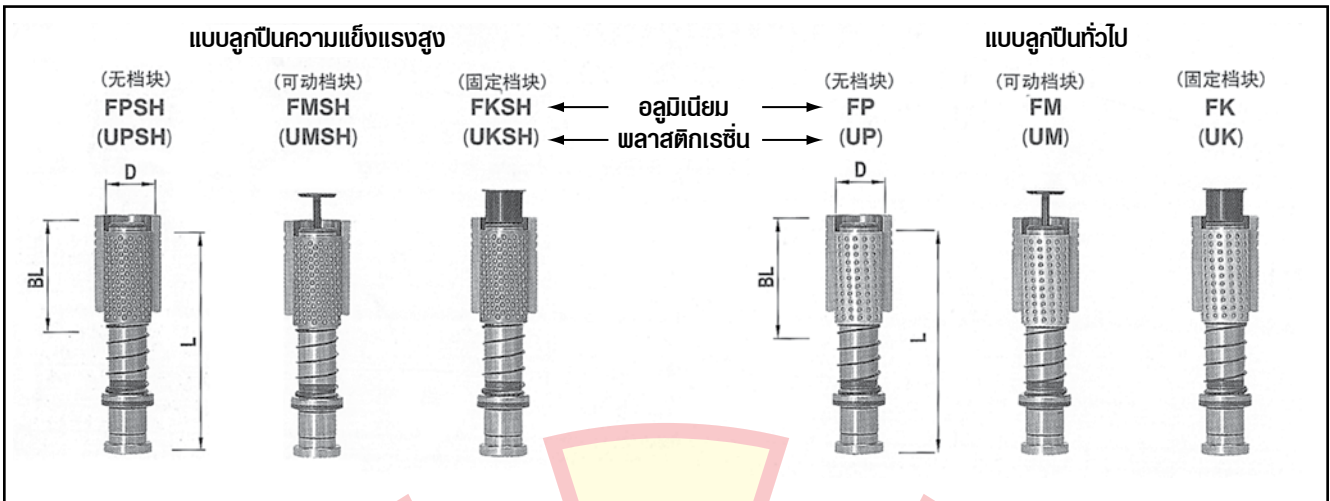

Catalog No.						
	①	②	③	④	⑤	⑥
FPSH	DRP				-	-
FMSH	DRPM		BBSH		DTM	-
FKSH	DRPK			DSWP	-	DTK
UPSH	DRP	DBB			-	-
UMSH	DRPM		BBJH		DTM	-
UKSH	DRPK				-	DTK
FP	DRP				-	-
FM	DRPM		BBS		DTM	-
FK	DRPK	DBB		DSWP	-	DTK
UP	DRP				-	-
UM	DRPM		BBJ		DTM	-
UK	DRPK				-	DTK

DRP • DRPM • DRPK													
D	D1	L1	L2	H	H1	H2	T	t	M	R	อื่นๆ		
20	+0.020 +0.015	28	15	10	14	7	8	5	8	1.6	8 x 18	2.0	CB8 - 25
22		30	16										
25		35	18										
28	+0.025 +0.020	36	20	12	16	8	10	10	10	2.0	10 x 22	3.5	CB10 - 30
32		40	23										
38	+0.030 +0.025	49	27	15	18	10	12	12	12	2.0	12 x 27	4.0	CB12 - 35
45		55	32										
50	+0.035 +0.030	62	35	15	20	12	14	15	15	2.0	14 x 31	4.5	CB14 - 40
60		72	42										

DBB		
d	D	Dh4
26	37	0 -0.007
28	40	
31	45	
36	50	0 -0.008
40	55	
48	64	
55	74	0 -0.010
60	83	
70	95	

RL	S	l1
50	0~19	15
60	0~23	20
75	0~30	25
90	0~37	30
100	0~47	35

D
 Standard Components
 For Press Dies



BALL BEARING GUIDE POST SETS - PRESS FIT POST - SPEC & PRICE

Catalog No.		L					② DBB		RL	④ FL		
Type	D						Type	BL				
FPSH FMSH FKSH UPSH UMSH UKSH FP FM FK UP UM UK	20	80	90	100	110	120	DBB	50	50	40 ~ 080		
	22	80	90	100	110	120		50	50	45 ~ 150		
	25	80	90	100	110	120		130	60	60	55 ~ 150	
	28	100	110	120	130	140		150	160	60		60
										80	75	
	32	120	130	140	150	160				60	60	55 ~ 150
										80	75	
	38	140	150	160	170	180				80	75	55 ~ 150
										100	90	
	45	140	150	160	170	180				100	90	55 ~ 150
										120	110	
	50	160	170	180	200					100	90	55 ~ 150
120							110					
60	160	170	180	200				100	90	85 ~ 200		
								120	110			

D	L	ราคา									
		แบบลูกปืนความแข็งแรงสูง					แบบลูกปืนทั่วไป				
		FPSH	FMSH FKSH	UPSH	UMSH UKSH	FP	FM	FK	UP	UM	UK
		L	L	L	L	L	L	L	L	L	L
20	080 ~ 100										
	110 ~ 120										
22	080 ~ 100										
	110 ~ 120										
25	080 ~ 100										
	110 ~ 130										
28	100 ~ 130										
	140 ~ 160										
32	120 ~ 140										
	150 ~ 160										
38	140 ~ 160										
	170 ~ 180										
45	140 ~ 160										
	170 ~ 180										
50	160 ~ 170										
	180 ~ 200										
60	160 ~ 170										
	180 ~ 200										

Type	M	H	S
DSP	M SUJ2	S S45C	
DSPM	H 58HRC		
DSPK			
DTM	M S45C	S Fe ₃ O ₄	
DTK	M S45C	S Fe ₃ O ₄	CB

Type	M	H
DBB	M SUJ2	H 58HRC-
BBSH	M A5052S/อลูมิเนียม	
BBS		

Type	M
BBJH	M POM/พลาสติกเรซิน
BBJ	
DSWP	M SWP-B



GUIDE POSTS / OIL-FREE GUIDE BUSHINGS

ไกด์โพสต์ / ไกด์บุชแบบไม่ใช้น้ำมัน (กราไฟท์)

ไกด์โพสต์

GPM

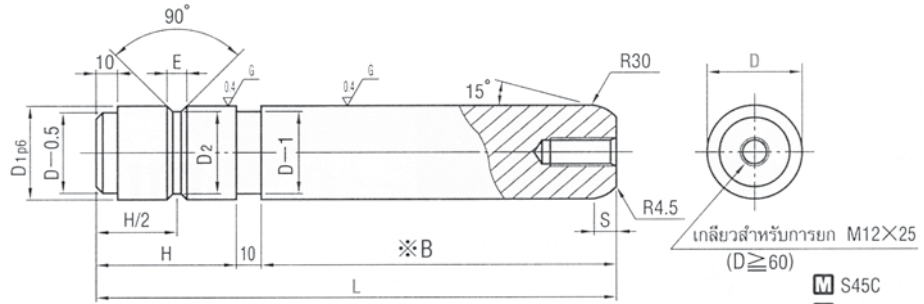

※ ส่วน B : การชุบผิวแข็ง (Quenching) ด้วยไฟฟ้าที่ความถี่สูง

M S45C
H 55HRC~
 (ชุบแข็งด้วยการชักนำกระแสไฟฟ้าในสนามแม่เหล็ก)

D	D1p6	D2	H	E	S	Catalog No.		L	ราคา	
						Type	D			
30	30	+0.035 +0.022	26	40	8	5	GPM	30	100	
									120	
									140	
									160	
									180	
40	40	+0.042 +0.026	36	50	10	10		50	120	
									140	
									160	
									180	
									200	
50	50	+0.042 +0.026	45	70	12	10	100	160		
								180		
								200		
								250		
								300		
60	60	+0.051 +0.032	55	90	12	10	80	200		
								220		
								250		
								300		
								350		
80	80	+0.051 +0.032	75	120	12	10	100	250		
								300		
								350		
								400		
								450		
100	100	+0.059 +0.037	95	150	12	10	100	300		
								350		
								400		
								450		
								500		

D
 Standard Components
 For Press Dies

ไกด์บุชแบบไม่ใช้น้ำมัน (กราไฟท์)

GBF (แบบเหล็ก)

GBW (แบบคอปเปอร์อัลลอย)

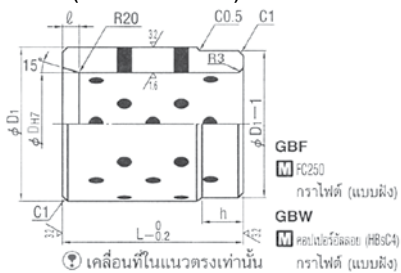

D1	Dh7	L	h	ℓ	Catalog No.		ราคา	
					Type	D	GBF	GBW
50	±0.008	30	+0.021 0	50	GBF (แบบเหล็ก)	*30		
60	±0.0095	40	+0.025 0	60		40		
70		50		75		15		
80	±0.001	60	+0.030 0	90		20		
100		80		120				
120	±0.0125	100	+0.035 0	150	GBW (แบบคอปเปอร์อัลลอย)	*100		
140		120		180			*200	



ปลอกลูกปืนพลาสติก

BALL RETAINER PMS

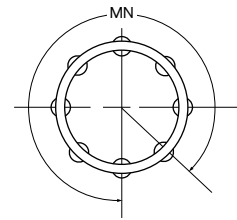
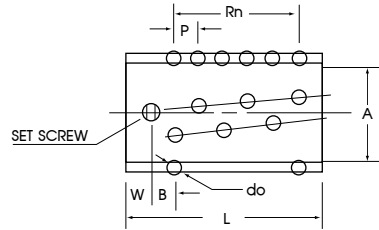
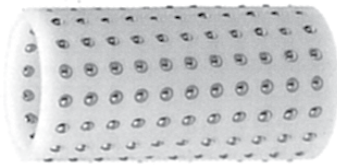

ITEM	A	L	Do	MN	RN	BALLS	R	W	PRICE
PBR20-50	20	50	3	12	8	96	5.50	5.75	
PBR20-60	20	60	3	12	10	120	5.50	5.25	
PBR22-50	22	50	3	14	8	112	5.50	5.75	
PBR22-60	22	60	3	14	10	140	5.50	5.25	
PBR25-50	25	50	3	16	8	128	5.50	5.75	
PBR25-60	25	60	3	16	10	160	5.50	5.25	
PBR25-75	25	75	3	16	13	208	5.45	4.80	
PBR28-60	28	60	4	14	8	112	6.50	7.25	
PBR28-75	28	75	4	14	11	154	6.40	5.50	
PBR32-60	32	60	4	16	8	128	6.50	7.25	
PBR32-75	32	75	4	16	11	176	6.50	6.70	
PBR32-90	32	90	4	16	13	208	6.50	6.00	
PBR36-85	36	90	4	16	12	192	6.50	6.75	
PBR38-70	38	70	5	16	8	128	8.00	7.00	
PBR38-75	38	75	5	16	8	128	8.00	6.50	
PBR38-90	38	90	5	16	11	176	7.90	5.50	
PBR38-95	38	95	5	16	11	185	7.90	5.50	
PBR50-90	50	90	5	20	11	220	7.90	5.50	
PBR50-100	50	100	5	20	13	240	8.00	6.00	
PBR50-110	50	110	5	20	13	260	8.00	7.00	

D

Standard Components
For Press Dies

ปลอกลูกปืนอลูมิเนียม

BALL RETAINER AMS

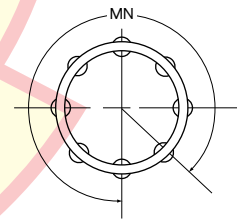
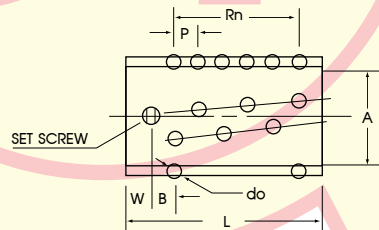
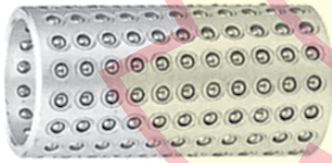

ITEM	A	L	Do	MN	RN	BALLS	P	W	PRICE
AMS20-50	20	50	3	12	8	96	5.50	5.75	
AMS20-60	20	60	3	12	10	120	5.50	5.25	
AMS22-50	22	50	3	14	8	112	5.50	5.75	
AMS22-60	22	60	3	14	10	140	5.50	5.25	
AMS25-50	25	50	3	16	8	128	5.50	5.75	
AMS25-60	25	60	3	16	10	160	5.50	5.25	
AMS25-75	25	75	3	16	13	208	5.45	4.80	
AMS32-60	32	60	4	16	8	128	6.50	7.25	
AMS32-75	32	75	4	16	11	176	6.50	6.70	
AMS32-90	32	90	4	16	13	208	6.50	6.00	
AMS38-70	38	70	5	16	8	128	8.00	7.00	
AMS38-75	38	75	5	16	8	128	8.00	6.50	
AMS38-90	38	90	5	16	11	176	7.90	5.50	
AMS38-95	38	95	5	16	11	185	7.90	5.50	
AMS50-90	50	90	5	20	11	220	7.90	5.50	
AMS50-100	50	100	5	20	12	240	8.00	6.00	
AMS50-110	50	110	5	20	13	260	8.00	7.00	



S.T. MODERNTOL CO., LTD.

TEL. 0 2417-0840 (จัดในมัติ 8 สาย) FAX: 662-417-1441, 662-417-1484-5

สลักแม่พิมพ์ปั๊ม / บิวซ์ แม่พิมพ์ปั๊ม

STRIPPER GUIDE PINS / BUSHINGS

<p>SGPH</p>	<p>材質 SUJ2 硬度 58HRC~</p>																																																																																
<p>SGOH</p>	<p>槽部详图</p> <table border="1" style="float: right; margin-left: 20px;"> <thead> <tr> <th colspan="2">จำนวนรู</th> <th colspan="8"></th> </tr> <tr> <th>D</th> <th>L</th> <th>40-</th> <th>50-</th> <th>70-</th> <th>80-</th> <th>90-</th> <th>160-</th> <th>180-</th> <th></th> </tr> </thead> <tbody> <tr> <td>8</td> <td>2</td> <td>3</td> <td>4</td> <td>5</td> <td>6</td> <td>-</td> <td>-</td> <td>-</td> <td></td> </tr> <tr> <td>10</td> <td>2</td> <td>3</td> <td>4</td> <td>5</td> <td>6</td> <td>-</td> <td>-</td> <td>-</td> <td></td> </tr> <tr> <td>13</td> <td>2</td> <td>3</td> <td>4</td> <td>5</td> <td>6</td> <td>7</td> <td>8</td> <td></td> <td></td> </tr> <tr> <td>16</td> <td>2</td> <td>3</td> <td>4</td> <td>5</td> <td>6</td> <td>7</td> <td>8</td> <td></td> <td></td> </tr> <tr> <td>20</td> <td>2</td> <td>3</td> <td>4</td> <td>5</td> <td>6</td> <td>7</td> <td>8</td> <td></td> <td></td> </tr> <tr> <td>25</td> <td>2</td> <td>3</td> <td>4</td> <td>5</td> <td>6</td> <td>7</td> <td>8</td> <td></td> <td></td> </tr> </tbody> </table> <p>材質 SUJ2 硬度 58HRC~</p> <p>*L40~119.5 → F=80 L120-L (C) max. → F=10</p>	จำนวนรู										D	L	40-	50-	70-	80-	90-	160-	180-		8	2	3	4	5	6	-	-	-		10	2	3	4	5	6	-	-	-		13	2	3	4	5	6	7	8			16	2	3	4	5	6	7	8			20	2	3	4	5	6	7	8			25	2	3	4	5	6	7	8		
จำนวนรู																																																																																	
D	L	40-	50-	70-	80-	90-	160-	180-																																																																									
8	2	3	4	5	6	-	-	-																																																																									
10	2	3	4	5	6	-	-	-																																																																									
13	2	3	4	5	6	7	8																																																																										
16	2	3	4	5	6	7	8																																																																										
20	2	3	4	5	6	7	8																																																																										
25	2	3	4	5	6	7	8																																																																										

Dm5	R	B	Catalog No.		L	ราคา	
			Type	D		SGPH	SGOH
8	+0.012 +0.007	1.5	10	8	40 50 60		
					70 80		
10	+0.015 +0.007	1.0	13	10	40 50 60 70 80		
					90 100		
13	+0.017 +0.008	2.0	16	13	40 50 60 70		
					80 90 100		
16	+0.017 +0.008	2.0	20	16	50 60 70 80		
					90 100 110 120		
20	+0.017 +0.008	2.0	25	20	60 70 80 90 100		
					110 120		
25	+0.017 +0.008	2.0	28	25	70 80 90 100		
					110 120		
						130 140	

 SGBA	<p>材質 SUJ2 硬度 58HRC~</p>
 SGBH	<p>材質 SUJ2 硬度 58HRC~</p>
 SGBL	<p>材質 SUJ2 硬度 58HRC~</p>
 SGBT	<p>材質 SUJ2 硬度 58HRC~</p>

Dm5	Catalog No.		L	ราคา	
	Type	D			
12	SGBA	8	10 13 16 20		
14		+0.020 +0.012	10	10 13 16 20 25	
18		13	13 16 20 25		
22		+0.024 +0.015	16	16 20 25 30	
25		20	20 25 30		
32		+0.020 +0.017	25	25 30 35	
Dm5	Catalog No.		L	ราคา	
	Type	D			
12	SGBH	8	10 13 16 20		
14		+0.015 +0.007	10	10 13 16 20 22 25	
18		13	13 16 20 22 25 30 35		
22		+0.017 +0.008	16	13 16 20 22 25 30 35	
25		20	16 20 22 25 30 35		
32		+0.020 +0.009	25	20 22 25 30 35	
Dm5	Catalog No.		L	ราคา	
	Type	D			
12	SGBL	8	10 13 16 20		
14		0 -0.005	10	10 13 16 20 22 25	
18		13	13 16 20 22 25 30 35		
22		16	13 16 20 22 25 30 35		
25		0 -0.006	20	16 20 22 25 30 35	
32		0 -0.007	25	20 22 25 30 35	
Dm5	Catalog No.		L	ราคา	
	Type	D			
12	SGBT	8	10 13 16 20		
14		0 -0.005	10	10 13 16 20 22 25	
18		13	13 16 20 22 25 30 35		
22		16	13 16 20 22 25 30 35		
25		0 -0.006	20	16 20 22 25 30 35	
32		0 -0.007	25	20 22 25 30 35	

D
Standard Components
For Press Dies



สลักโดเวลพิน แบบตัน

DOWEL PINS STRAIGHT TYPE

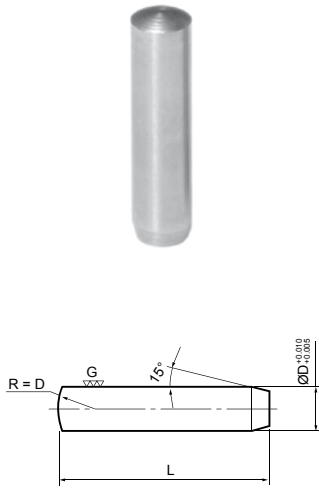

M S50C
H 58 HRC

Code	D	L	ราคา
DPS	3	10 15 20	
		25 30 40	
	4	10 15 20	
		25 30 35 40 45 50	
	5	20 25 30 10 15 35 40 45 50 60	
	6	20 25 30 35 40	
		45 50 55 60 10 15 70	
8	20 25 30 35 40 45 50 55 60 10 15 70 80 100		
10	20 25 30 35 40 45 50 55 60 70 80		
	15 100		
12	20 25 30 35 40 45 50 55 60 70 80		

สลักโดเวลพินแบบมีรูเกลียว

DOWEL PINS TAPPED HOLE TYPE

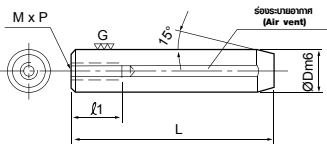

M S50C
H 45 HRC

Code	D	M x P	l1	L	ราคา
6	4 x 0.7	8	8	20 25 30 35 40	
				10 15 45 50	
8	5 x 0.8	10	10	20 25 30 35 40 45 50 55 60	
				15 65 70 80	
10	6 x 1.0	12	12	30 35 40 45 50 55 60	
				15 20 25 70 80 100	
12	8 x 1.25	15	15	20 25 30 35 40 45 50 55 60	
				70 80 100	
13	10 x 1.5	18	18	40 45 50 60 70	
				80	
16	12	20	20	40 50 60 70 80	
				80	
20	16	25	25	50 60 70 80	
				80	

D

Standard Components
For Press Dies



ปลอกใส่สกรูสำหรับแม่พิมพ์บีบ

等高套筒
JCSR型
STRIPPER
BUSHING-JCSR
TYPE

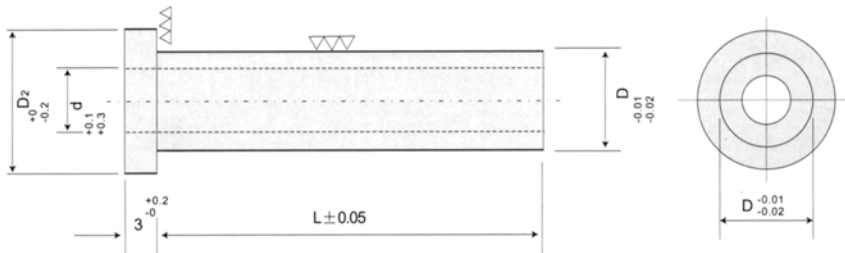

JCSR	材质: S45C	硬度: 45HRC~
	MATERIAL	HARDNESS

Price

公差:mm

d	D ²	Catalog No.		Unit price													
		Code	D	L25	L30	L35	L40	L45	L50	L55	L60	L65	L70	L80	L90	L100	
6	13	JCSR	9														
8	16		11														
10	18		13														

使用例:

特点:

- 1.使用套筒上螺丝后旋紧可防止螺丝松动。
- 2.因套筒的螺丝能固定脱料板与冲头板之间的距离,故模具的拆装之间能做到准确快速的目的。

Example :

Features

1. Use sleeve and tighten it after loading a screw to prevent movement of screw
2. As the screw of sleeve defines the distance between stripper plate and punch plate,so it provides precise and prompt diepacking and detachment

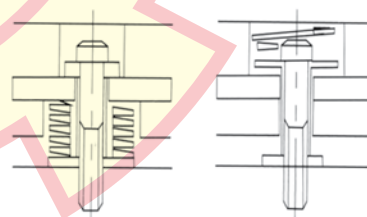

D
Standard Components
For Press Dies

Order Format	Code	d	D	L	Q'TY
	JCSR	6	9	50	50 支 pcs



ST พืนด STRAIGHT PUNCHES

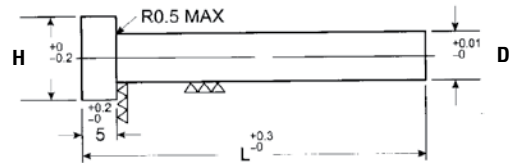

MATERIAL: SKD-11
HARDNESS: HRC 60°- 62°
CODE : STD

SIZE		L						
D	H	40	50	60	70	80	90	100
1	2							
1.5	3							
2	4							
2.5	4.5							
3	5							
3.5	5.5							
4	7							
4.5	6.5							
5	8							
5.5	7.5							
6	9							
6.5	8.5							
7	10							
8	11							
9	12							
10	13							
11	14							
12	15							
13	16							
14	17							
15	18							
16	19							
18	21							
20	23							
25	28							

MATERIAL: SKH-51
HARDNESS: HRC 61°- 64°
CODE : STH

SIZE		L						
D	H	40	50	60	70	80	90	100
1	2							
1.5	3							
2	4							
2.5	4.5							
3	5							
3.5	5.5							
4	7							
4.5	6.5							
5	8							
5.5	7.5							
6	9							
6.5	8.5							
7	10							
8	11							
9	12							
10	13							
11	14							
12	15							
13	16							
14	17							
15	18							
16	19							
18	21							
20	23							

D

Standard Components
For Press Dies



S.T. MODERNTOL CO., LTD.

TEL. 0 2417-0840 (อัตโนมัติ 8 สาย) FAX: 662-417-1441, 662-417-1484-5

ST พื้ 2 ตอน SHOULDER PUNCHES

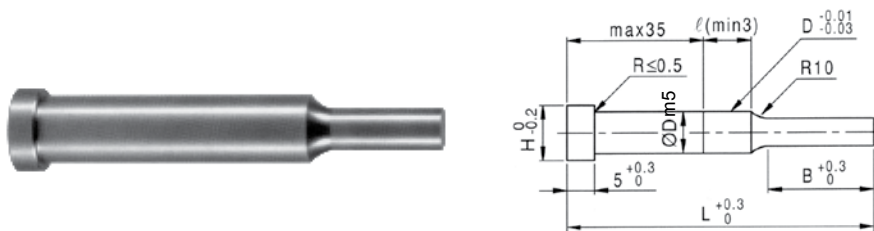

SP M SKD 11 SH M SKH 51
H 60-63 HRC H 61-64 HRC

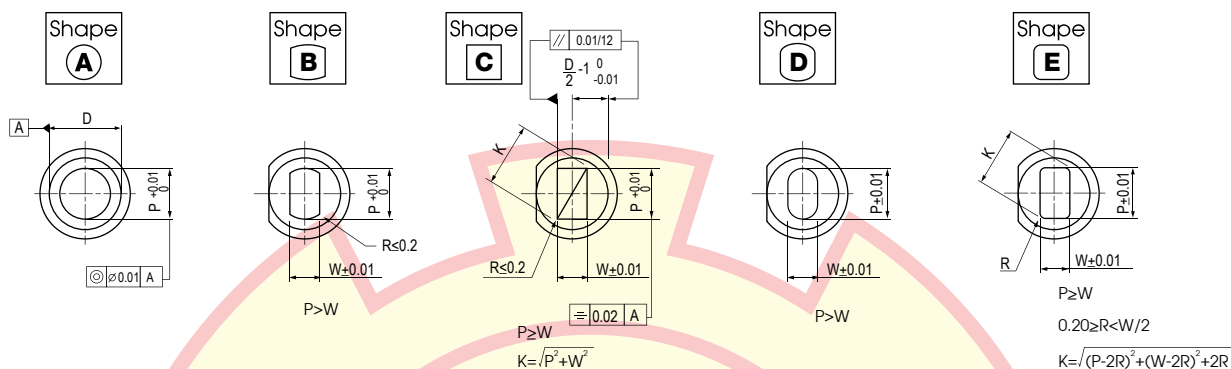

CODE	B Point length	Shape	∅D	L					↑ 0.01 mm.					B	H		
									A		E	I	O			U	U
									Min. P	max.	P.Kmax.	P.Wmin.	R				
SP SH (Dm5)	S ระยะคมตัด สั้น	A	3	40	50	60	70	80	1.00	2.99	2.97	0.70	0.20 ≤ R < W/2 (@ only)	8	5		
			4	40	50	60	70	80	1.00	3.99	3.97	1.00			7		
			5	40	50	60	70	80	2.00	4.99	4.97	1.20			8		
			6	40	50	60	70	80	2.00	5.99	5.97	1.50			9		
			8	(40)	50	60	70	80	90	100	3.00	7.99			7.97	2.00	13
			10	(40)	50	60	70	80	90	100	3.00	9.99		9.97	2.50	If L=(40) 13	
			13	(40)	50	60	70	80	90	100	6.00	12.99		12.97	3.00	16	
			16	(40)	50	60	70	80	90	100	10.00	15.99		15.97	4.00	19	
			20	(40)	50	60	70	80	90	100	13.00	19.99		19.97	5.00	If L=(40) 23	
			25	(40)	50	60	70	80	90	100	18.00	24.99		24.97	6.00	28	
	L ระยะคมตัด ยาว	D	3	50	60	70	80	1.00	2.99	2.97	0.70	0.20 ≤ R < W/2 (@ only)	13	5			
			4	50	60	70	80	1.00	3.99	3.97	2.00			7			
			5	50	60	70	80	2.00	4.99	4.97	2.00			8			
			6	50	60	70	80	2.00	5.99	5.97	2.00			9			
			8	50	60	70	80	90	100	3.00	7.99			7.97	2.50	11	
			10	50	60	70	80	90	100	3.00	9.99		9.97	2.50	19		
			13	50	60	70	80	90	100	6.00	12.99		12.97	3.00	16		
			16	60	70	80	90	100	10.00	15.99	15.97		4.00	19			
			20	60	70	80	90	100	13.00	19.99	19.97		5.00	25			
			25	60	70	80	90	100	18.00	24.99	24.97		6.00	28			
	X ระยะคมตัด ยาวพิเศษ	A	3	50	60	70	80	1.20	2.99	-	-	-	19	5			
			4	50	60	70	80	1.20	3.99	-	-			7			
			5	60	70	80	2.00	4.99	-	-	8						
			6	60	70	80	2.00	5.99	-	-	9						
			8	60	70	80	90	100	3.00	7.99	-		-	11			
10			60	70	80	90	100	3.00	9.99	-	-		13				
13			60	70	80	90	100	6.00	12.99	-	-		16				
16			70	80	90	100	10.00	15.99	-	-	19						
20			70	80	90	100	13.00	19.99	-	-	23						
25	70	80	90	100	18.00	24.99	-	-	28								

Order : CODE ∅D x L x P x W x R (@ only) = Pcs.
SPLB 13 x 80 x P10.50 x W7.34 = 1

D
Standard Components
For Press Dies



ST พื้ 2 ตอน SHOULDER PUNCHES

∅D	ราคาพื้ 2 ตอน											
	SP M SKD11						SH M SKH51					
	SPSA SPLA	SPXA	SPSB SPLB	SPSC SPLC	SPSD SPLD	SPSE SPLE	SHSA SHLA	SHXA	SHSB SHLB	SHSC SHLC	SHSD SHLD	SHSE SHLE
3												
4												
5												
6												
8												
10												
13												
16												
20												
25												

ST พื้ตรง STRAIGHT PILOT PUNCHES

ปลายมน

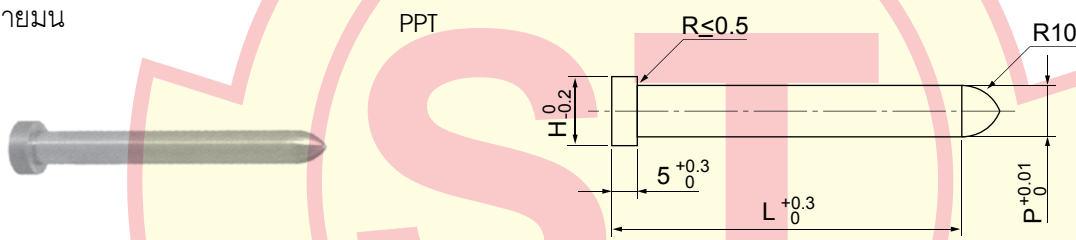

M SKD 11
H 60-63 HRC

ปลายเทเปอร์

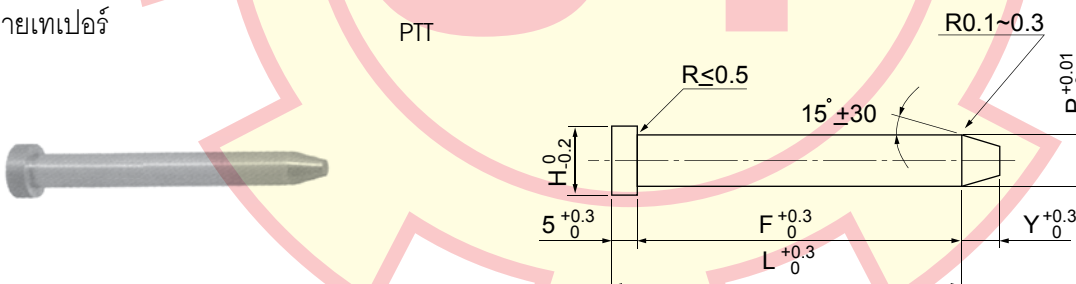

M SKD 11
H 60-63 HRC

CODE	No.	L	P ↑0.01 mm.	H	Y	ราคา	
						PPT	PTT
PPT PTT	3	42 52 62 72 1	2.00 - 3.00	5	2		
	4	42 52 62 72 1	3.00 - 4.00	7			
	5	42 52 62 72 1	4.00 - 5.00	8	3		
	6	42 52 62 72 1	5.00 - 6.00	9			
	8	42 52 62 72 82 92	6.00 - 8.00	11			
	10	42 52 62 72 82 92	8.00 - 10.00	13	5		
	13	42 52 62 72 82 92 102	10.00 - 13.00	16			
16	42 52 62 72 82 92 102	13.00 - 16.00	19	8			

Order : CODE No. x L x P = Pcs.
PPT 3 x 42 x P2.5 = 1



ST ไพลอตพUNCH PILOT PUNCHES

ปลายมน



PPSA
PPLA
PPXA

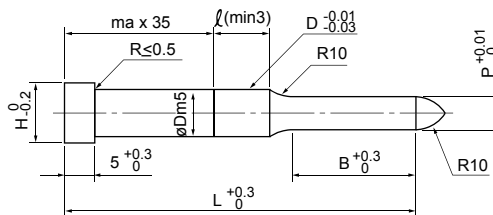

M SKD 11
H 60-63 HRC

ปลายเทเปอร์



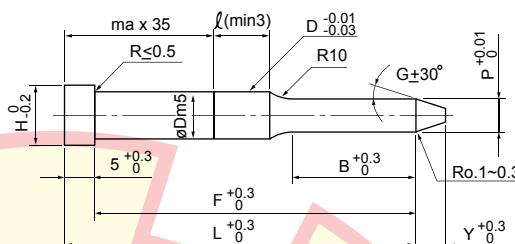

PTSA
PTLA
PTXA



P	G
P ≤ 1.99	10°
P ≥ 2.00	15°

M SKD 11
H 60-63 HRC

CODE	ØD	L	P ↑ 0.01 mm.	B	H	Y	สาร	
							PPSA	PTSA
S ค่า B สั้น (Dm5) PPSA PTSA 	3	42 52 62 72	1.00 - 2.99	10	5	2		
	4	42 52 62 72	1.00 - 3.99		7			
	5	42 52 62 72	2.00 - 4.99		8	3		
	6	(42) 52 62 72	2.50 - 5.99	9				
	8	(42) 52 62 72 82 92	3.00 - 7.99	15	11	5		
	10	(42) 52 62 72 82 92 102	3.00 - 9.99		13			
	13	(42) 52 62 72 82 92 102	6.00 - 12.99		16			
	16	(42) 52 62 72 82 92 102	10.00 - 15.99	21	19	8		
	20	(42) 52 62 72 82 92 102	13.00 - 19.99		23			
25	(42) 52 62 72 82 92 102	18.00 - 24.99	28					
L ค่า B ยาว (Dm5) PPLA PTLA 	3	52 62 72	1.00 - 2.99	15	5	2	PPLA	PTLA
	4	52 62 72	1.00 - 3.99		7			
	5	52 62 72	2.00 - 4.99		8	3		
	6	52 62 72	2.50 - 5.99	9				
	8	52 62 72 82 92	3.00 - 7.99	21	11	5		
	10	52 62 72 82 92 102	3.00 - 9.99		13			
	13	52 62 72 82 92 102	6.00 - 12.99		16			
	16	62 72 82 92 102	10.00 - 15.99	27	19	8		
	20	62 72 82 92 102	13.00 - 19.99		23			
25	62 72 82 92 102	18.00 - 24.99	28					
X ค่า B ยาวพิเศษ (Dm5) PPXA PTXA 	3	52 62 72	1.20 - 2.99	21	5	2	PPXA	PTXA
	4	52 62 72	1.20 - 3.99		7			
	5	62 72	2.00 - 4.99	27	8	3		
	6	62 72	2.50 - 5.99		9			
	8	62 72 82 92	3.00 - 7.99	32	11	5		
	10	62 72 82 92 102	3.00 - 9.99		13			
	13	62 72 82 92 102	6.00 - 12.99		16			
	16	72 82 92 102	10.00 - 15.99	42	19	8		
	20	72 82 92 102	13.00 - 19.99		23			
25	72 82 92 102	18.00 - 24.99	28					

Order : CODE ØD x L x P = Pcs.

PPSA 8 x 62 x P4.5 = 1

D
Standard Components
For Press Dies



ST ไทล์ฟเตอร์

GUIDE LIFTER PINS

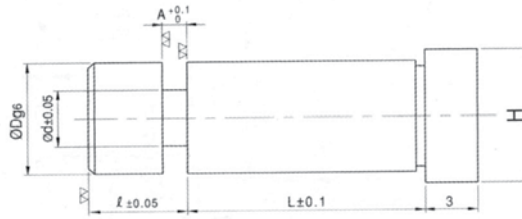

M SCM 440

H 53-58 HRC

ขนาดมาตรฐาน

CODE	∅Dg6	∅H	∅d	ℓ	L						A	ราคา					
GLF	6	-0.004 -0.012	8	3.6	7	22	25	28	30	33	36			1.0, 1.6			
	8	-0.005 -0.014	10	5.0		22	25	28	30	33	36	40			1.0, 2.0		
	10	-0.005 -0.014	13	6.0			25	28	30	33	36	40	50			1.6, 2.5	
	13	-0.006 -0.017	16	7.0	12		28	30	33	36	40	50			2.5, 3.6		
	16	-0.006 -0.017	19	8.0				30	33	36	40	50	60			2.5, 4.0	
	20	-0.007 -0.020	23	10.0					33	36	40	50	60			3.6, 5.0	

ขนาดตามสั่ง

CODE	∅Dg6	∅H	∅d	ℓ	L ↑ 0.1 mm.						A	ราคา	
GLFL	6	-0.004 -0.012	8	3.6	7	15.0 ~ 75.0						1.0 ~ 3.0	
	8	-0.005 -0.014	10	5.0		15.0 ~ 75.0						1.0 ~ 4.0	
	10	-0.005 -0.014	13	6.0		15.0 ~ 90.0						1.0 ~ 4.0	
	13	-0.006 -0.017	16	7.0	12	20.0 ~ 90.0						1.0 ~ 6.0	
	16	-0.006 -0.017	19	8.0		20.0 ~ 90.0						1.0 ~ 6.0	
	20	-0.007 -0.020	23	10.0		20.0 ~ 90.0						1.0 ~ 6.0	

เหล็กตีบ กลมแบบกลวง SUJ 2

รหัส	ขนาด	ยาว	ราคา
SU1808	18 x 8	1000	
SU2313	23 x 13	1000	
SU3018	30 x 18	1000	
SU3114	31 x 14	1000	
SU3317	33 x 17	1000	
SU3617	36 x 17	1000	
SU3924	39 x 24	1000	
SU4223	42 x 23	1000	
SU4428	44 x 28	1000	
SU4828	48 x 28	1000	

รหัส	ขนาด	ยาว	ราคา
SU5033	50 x 33	1000	
SU5533	55 x 33	1000	
SU5738	57 x 38	1000	
SU6233	62 x 33	1000	
SU6238	62 x 38	1000	
SU5138	51 x 38	1000	
SU7248	72 x 48	1000	
SU7748	77 x 48	1000	
SU7752	77 x 52	1000	
SU6646	66 x 46	1000	
SU8258	82 x 58	1000	
SU8557	85 x 57	1000	



S.T. MODERNTOL CO., LTD.

TEL. 0 2417-0840 (อัตโนมัติ 8 สาย) FAX: 662-417-1441, 662-417-1484-5

BUTTON DIES (LINER)

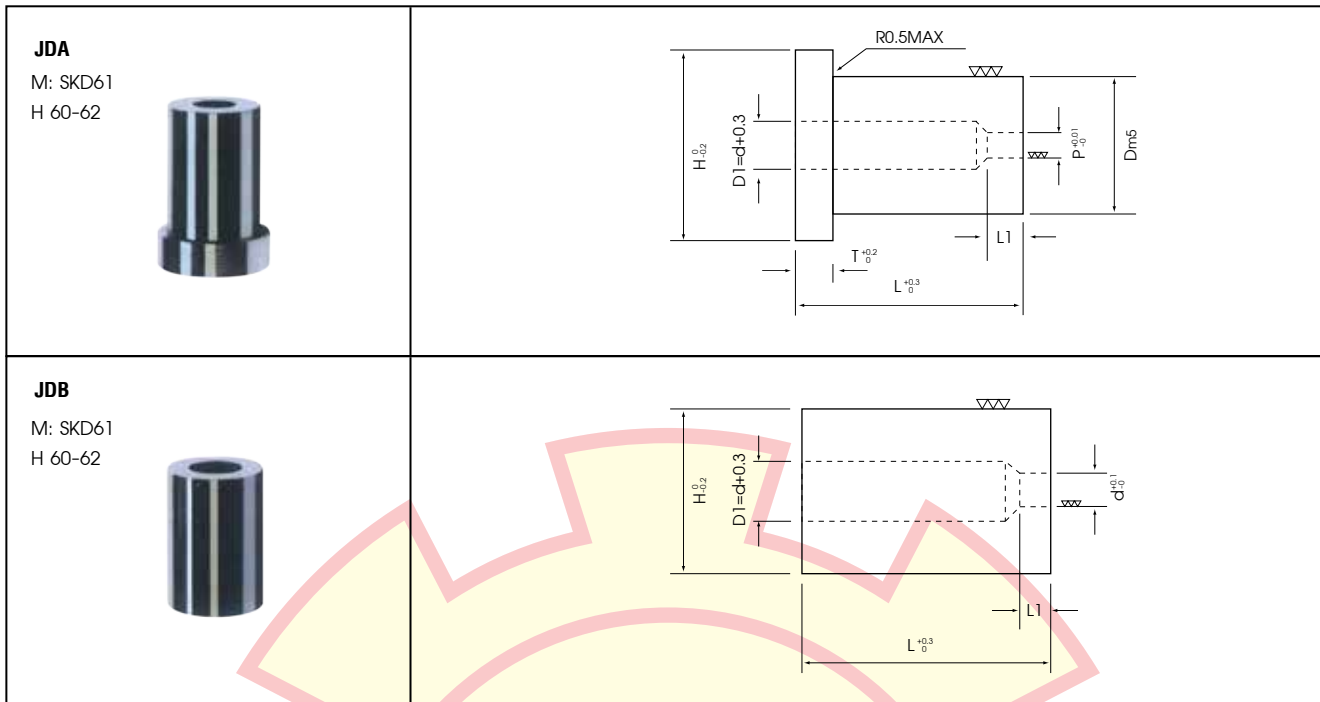

MAD / MBD	M : SKD11	HRC60° ~ 62°
-----------	-----------	--------------

Code	Dm5		H	L	P	L1	Unit Price		
							JDA	JDB	
JDA	6	+0.009 +0.004	9	20	1.00~3.00	3			
	8	+0.012 +0.007	11		1.00~4.00	4			
	10		13		2.00~6.00				
	13	+0.015 +0.007	16		3.00~8.00				
	16		19		5.00~10.00				
	18		21		6.00~11.00				
	JDB	20	+0.017 +0.008	23	45	7.00~12.00	5		
		22		25		8.00~14.00			
		25		28		10.00~16.00			
		28		31		13.00~18.00			
		30	+0.020 +0.009	33		14.00~19.00			
		32		35		15.00~20.00			

Order Format	Code	D	P	L	Q'TY
	JDA	13	7	30	50 pcs

D
 Standard Components
 For Press Dies



Aerial Cam Unit

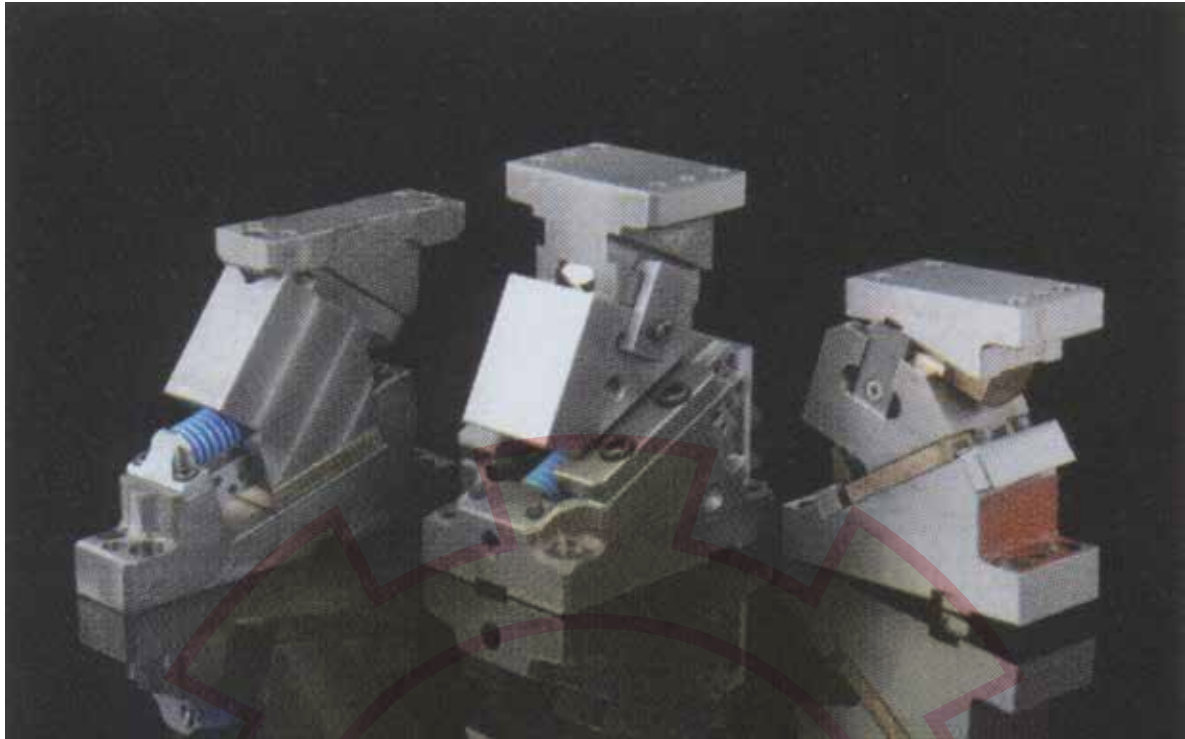

อะไหล่แม่พิมพ์รถยนต์

ขนาด	ราคา	ขนาด	ราคา	ขนาด	ราคา
Serie SKC52		Serie SUCD52		Serie KGSP300	
Serie SKC65		Serie HUCT65		Serie KCMSL500	
Serie SKC100		Serie UCMSC50		Serie KCMSL600	
Serie SKC150		Serie UCMSC65		Serie KCMSL700	
Serie SKC200		Serie UCMSC80		Serie KCMSL800	
Serie SKC250		Serie UCMSC150		Serie KCMSL900	
Serie SKC300		Serie UCMSG50		Serie KCMSL1000	
Serie SKC400		Serie UCMSG65		Serie KCMSK50	
Serie SKC500		Serie UCMSG80		Serie KCMSN50	
Serie SKC600		Serie UCMSG150		KSKC65	
Serie SOUK65		Serie UCMSG200		KSKC100	
Serie SOUK100		Serie UCMSG300		UPCM50	
Serie SOUK150		Serie UCMSN70		SACD52	
Serie SOUK200		Serie UCMSN80		SLSD52	
Serie SUWB200		Serie UCMSN165		SULNC65	
Serie SUWB300		Serie UCMSN200		MFV48	
Serie SUWB400		Serie UCMSN300		MFV65	
Serie SUWB500		Serie UCMSN400		MFV68	
Serie SUWB600		Serie KGSP50		MFV80	
Serie CMSA50		Serie KGSP80		MUC50	
Serie CMSD52		Serie KGSP150			
Serie CMSD90		Serie KGSP200			

D

Standard Components
For Press Dies



S.T. MODERNTOOL CO., LTD.

TEL. 0 2417-0840 (อัตโนมัติ 8 สาย) FAX: 662-417-1441, 662-417-1484-5

冷冲模座 SGP、TRP 外导柱组件

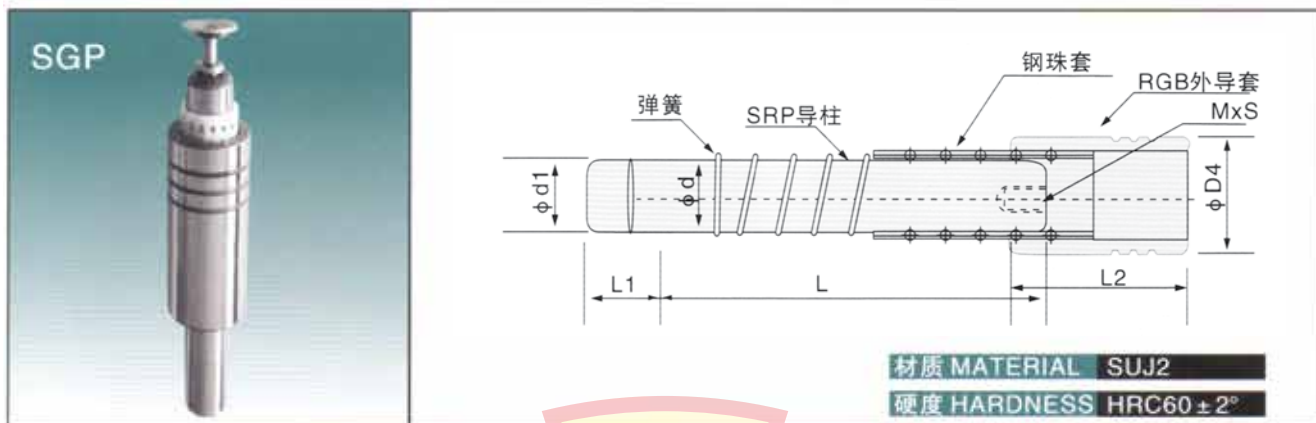

材质 MATERIAL SUJ2
 硬度 HARDNESS HRC60 ± 2°

基本尺寸	d		d _i		L ₁	M×S	L																			
	尺寸	公差	尺寸	公差			90	100	110	120	130	140	150	160	170	180	190	200	210	220	230	240	250	260		
19	19	-0.025	19		23	M6×15																				
20	20	-0.020	20																							
22	22	-0.020	22																							
25	25	-0.025	25		32	M8×20																				
28	28	-0.020	28	+0.025																						
32	32	-0.030	32	+0.035																						
36	36	-0.025	36		38	M10×20																				
38	38	-0.025	38																							
45	45	-0.035	45																							
50	50	-0.030	50																							
60	60	-0.030	60																							

※可按圖樣加工

订单格式:

代号	D	L	QTY
SGP	25	180	10支

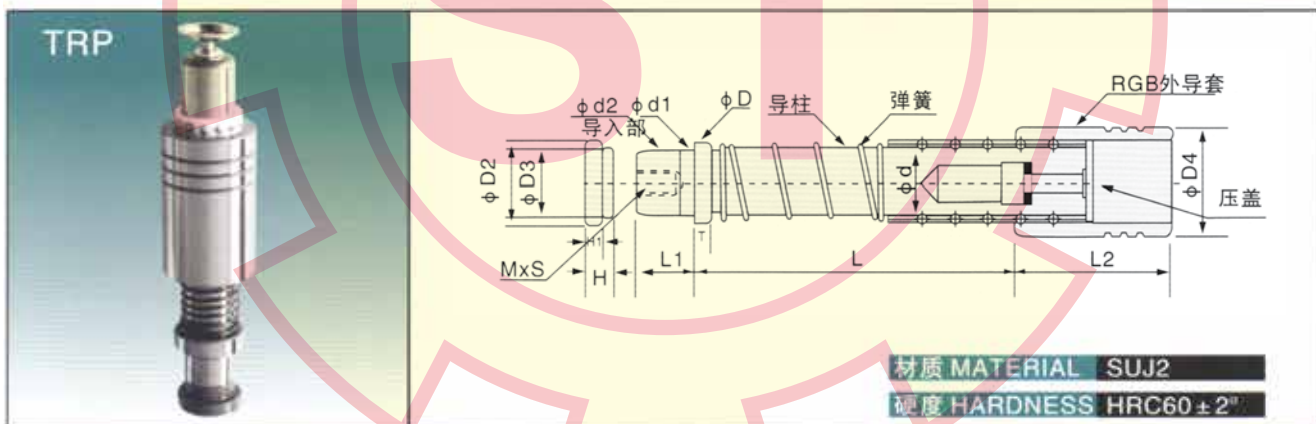

材质 MATERIAL SUJ2
 硬度 HARDNESS HRC60 ± 2°

外径 d	L																							
	100	105	110	115	120	125	130	135	140	145	150	155	160	165	170	175	180	185	190	195	200	205	210	
20																								
22																								
25																								
28																								
32																								
36																								
38																								
45																								
50																								
60																								

※可按圖樣加工

订单格式:

代号	D	L	QTY
TRP	25	180	10支

D

Standard Components
For Press Dies



RGB、PGB 导套



RGB

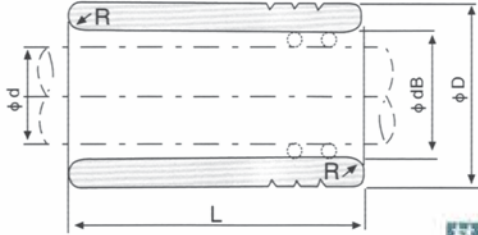

材质 MATERIAL SUJ2
硬度 HARDNESS HRC60±2°

基本尺寸	dB		D			L	单價
	尺寸	公差	尺寸	公差(緊密型)	公差(粘接型)		
19	25		37			60	
20	26		37	+0.015			
22	28	+0.035	44	+0.025		75	
25	31	+0.040	48				
28	34		54		+0.3	85	
32	40	+0.040	58		+0.4		
36	44	+0.045	63			95	
38	48		74	+0.015			
45	55	+0.040	78	+0.025		110	
50	60	+0.045	88				
56	70						

※可按圖樣加工

订单格式:

代号	D	L	QTY
RGB	25	60	10支



PGB

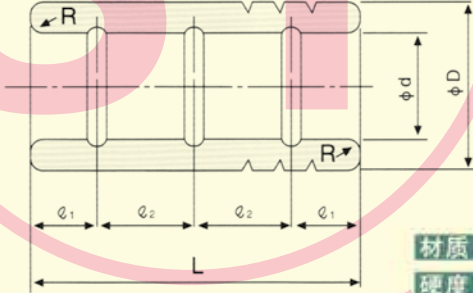

材质 MATERIAL SUJ2
硬度 HARDNESS HRC60±2°

基本尺寸	d		D		L	L1	L2	单價		
	尺寸	公差	尺寸	公差						
19	19		31		60	12	18			
20	20	+0.010	34	+0.015						
22	22	+0.015	37	+0.025	70	14	19.5			
25	25		40							
28	28		44		75	15	22.5			
32	32	+0.015	51	+0.015						
36	36	+0.020	63	+0.025	85	16	26.5			
38	38		78							
45	45	+0.015	68					110	17	30.5
50	50	+0.025								
60	60									

※可按圖樣加工

订单格式:

代号	D	L	QTY
PGB	25	60	10支



冲床安全手工工具 แม่เหล็กดูดชิ้นงาน

- 1、本產品可吸非金屬制品，如銅、不銹鋼、電路板、紙卡。
- 2、吸力特強、操作與磁鐵工完全相同、更省力提高工作效力。
- 3、免動力、減少空壓機用量、不刮傷產品、提升產量品質。



型號	G01	G02	G03	G011	G12	G20	G21	G22
吸力(kg)	1.5	3	5	5	3	1.5	1.5~3	3~5

D

Standard Components
For Press Dies



冲床压板 · 四角头螺丝

平型MC-A



弯型MC-B



型 式	MC-12A	MC-16A	MC-20A	MC-24A
螺絲孔徑	12mm (1/2")	16mm (5/8")	20mm (3/4")	24mm (1")
長 度	105mm	125mm	155mm	180mm
寬 度	57mm	62mm	65mm	78mm
螺絲直徑長度	1/2" x 3"	5/8" x 4"	3/4" x 5"	1" x 6"
可夾最低	8	12	16	23
可夾最高	40	55	70	80
螺絲A x B x C	25 x 30 x 10	30 x 36 x 12	34 x 40 x 12	41 x 50 x 17
單 價				

型 式	MC-12B	MC-16B	MC-20B	MC-24B
螺絲孔徑	12mm (1/2")	16mm (5/8")	20mm (3/4")	24mm (1")
長 度	85mm	130mm	155mm	190mm
寬 度	50mm	57mm	68mm	75mm
螺絲直徑長度	1/2" x 4"	5/8" x 5"	3/4" x 6"	1" x 7"
可夾最低	0	0	0	0
可夾最高	40	55	70	80
螺絲A x B x C	25 x 30 x 10	30 x 36 x 12	34 x 40 x 12	41 x 50 x 17
單 價				

特點：壓板使用(MALLEABLE CAST IRON)材料鑄造而成，彈性、壓力，達到使用標準，免除一切使用墊片之煩惱、省時、增加工作效率、提高生產量(衝床、刨床、銑床、油壓機械)皆可使用。

特性：使用高級MALLEABLE CAST IRON鑄造而成，堅韌，永不斷裂，促使模具或其他工作固定、便捷、牢固。

D

Standard Components
For Press Dies

四角頭螺絲

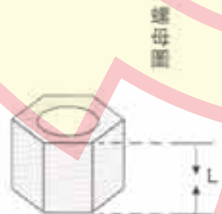

品名	規格	1/2"				5/8"				3/4"				1"			
		長度	單價														
螺 杆	2"																
	2 1/2"																
	3"																
	3 1/2"																
	4"																
	4 1/2"																
	5"																
	5 1/2"																
	6"																
	7"																
	8"																
	9"																
	10"																
	12"																
14"																	

订单格式:

代号	D	L	Q'TY
MC-A	1/2	3"	10支

LM 螺母	尺寸	規格			
		1/2"	5/8"	3/4"	1"
	MXL(mm)	21 x 20	26 x 22	32 x 25	41 x 30
	單 價				



บุชทองเหลืองกราฟไฟต์

OIL FREE COMPONENTS



* รับสั่งทำตามแบบ

D

Standard Components
For Press Dies

